

LM3914, LM3915 Dot/Bar Display Drivers Macro Model

Driver Output Characteristics

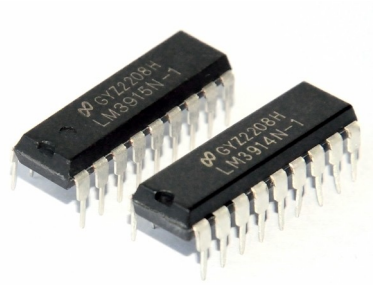
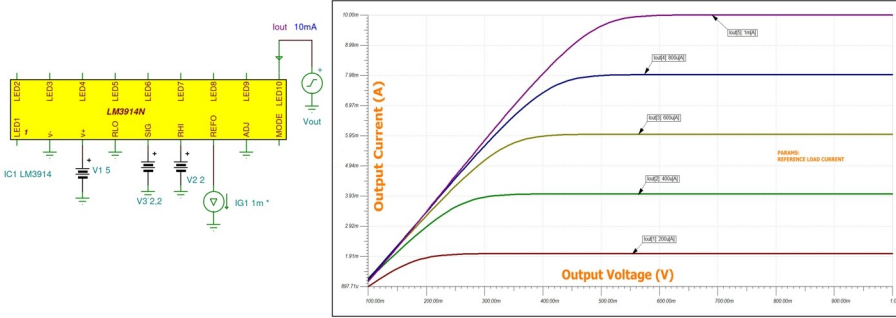

Dot Display

The photo probably shows (working) counterfeits. The LM3914N has a reference voltage of 1.23 V, the LM3915 1.28 V. The latter is the same as the original factory specification. The model follows the original specification, so the reference voltage is 1.28 V.

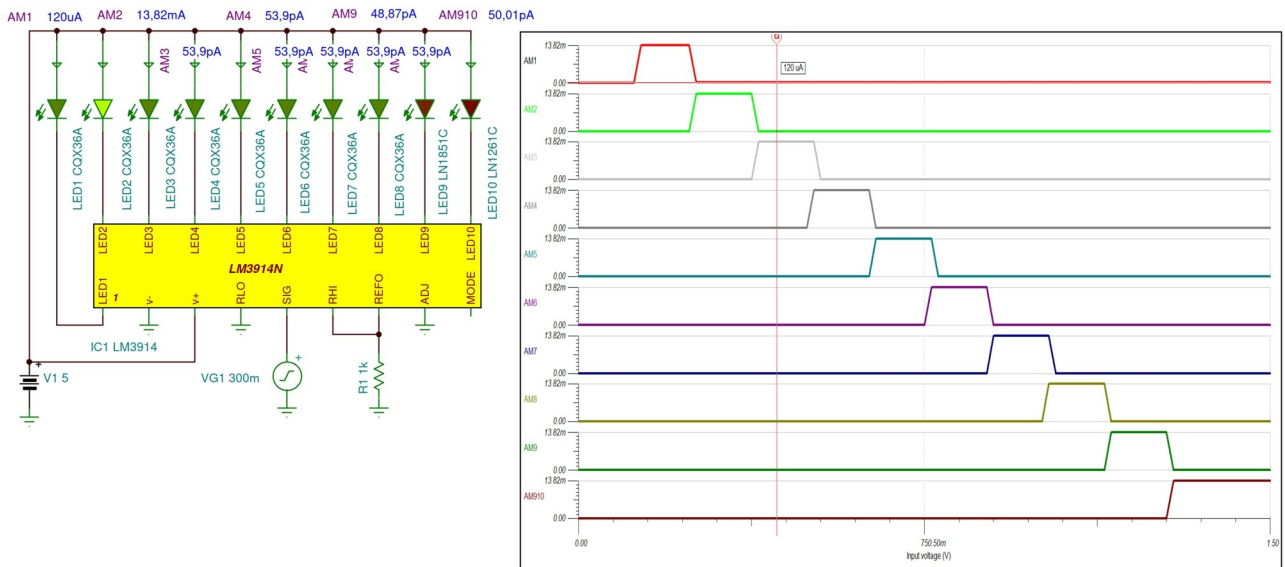

Bar Graph Display

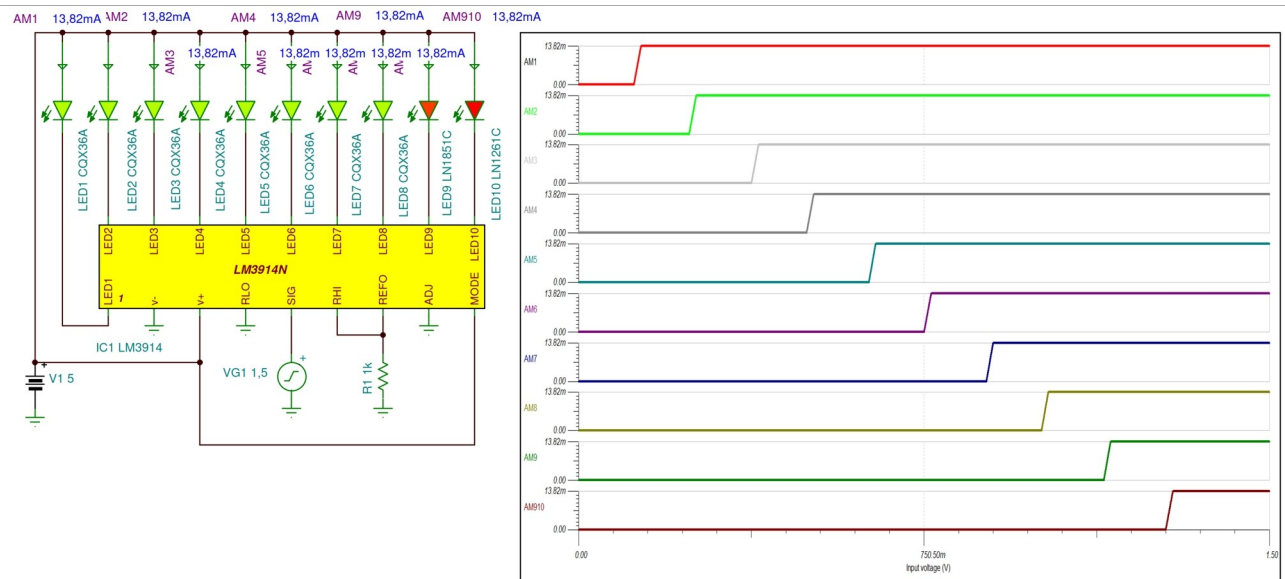

Cascading LM3914s in Dot Mode

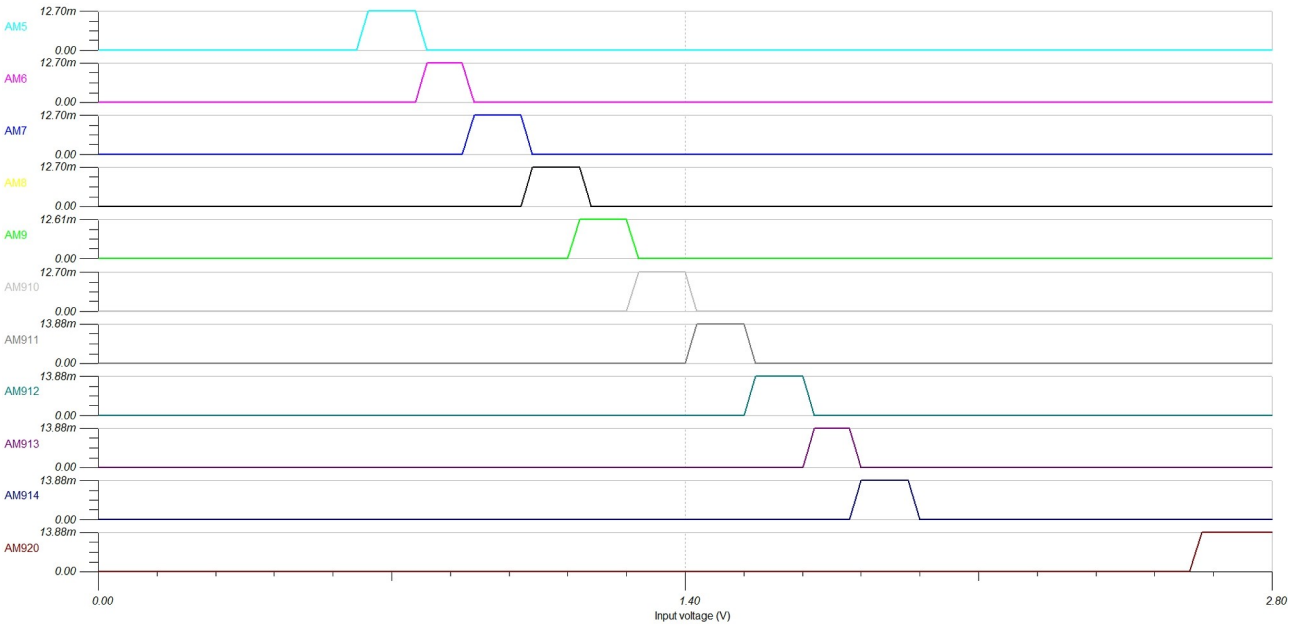
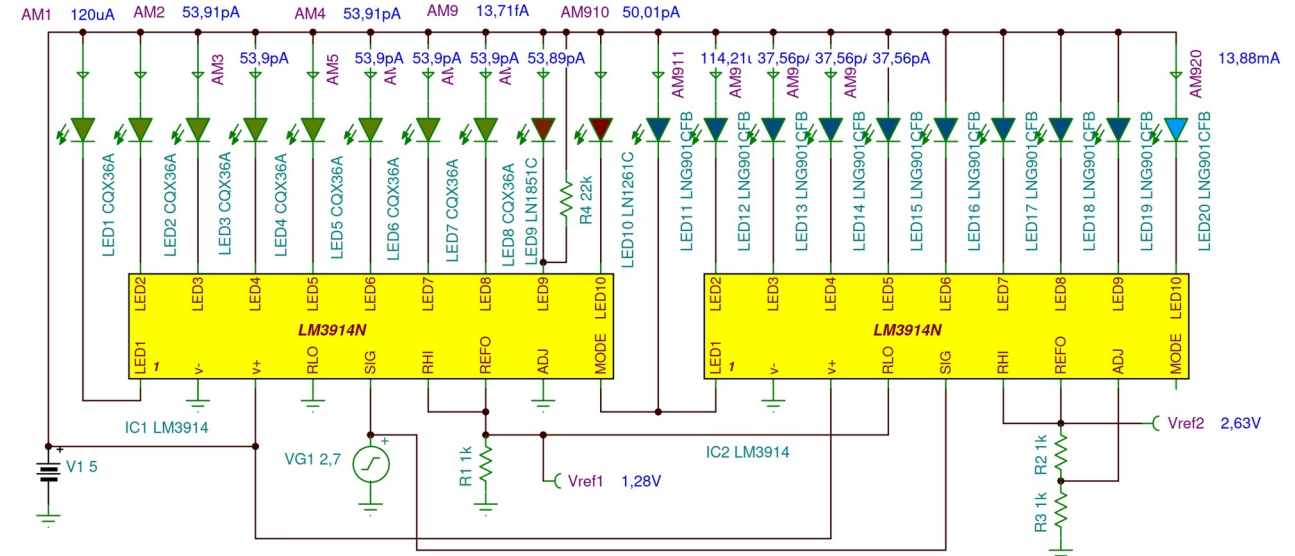

LM3915 Dot Display (logarithmic 3 dB/step analog display)

